



TURNKEY SOLUTIONS

HITEC PRODUCTS GROUP IS A NORWEGIAN OWNED COMPANY WITH HEAD OFFICE IN STAVANGER.

HITEC PRODUCTS DEVELOPS AND DELIVERS ELECTRO HYDRAULIC CONTROL SYSTEMS, CHEMICAL INJECTION SYSTEMS AND DRILLING SYSTEMS TO THE ENERGY INDUSTRY.

THE MAIN MARKET SEGMENTS WE SUPPLY TO ARE:

- SUBSEA DEVELOPMENTS
- TOPSIDE PLATFORMS / FPSO
- MAINTENANCE & MODIFICATIONS
- PROCESS INDUSTRY
- WELL INTERVENTION / COMPLETION
- WELL SERVICE
- DRILLING RIGS
- ONSHORE PETROCHEMICAL
- OIL & GAS PIPELINES

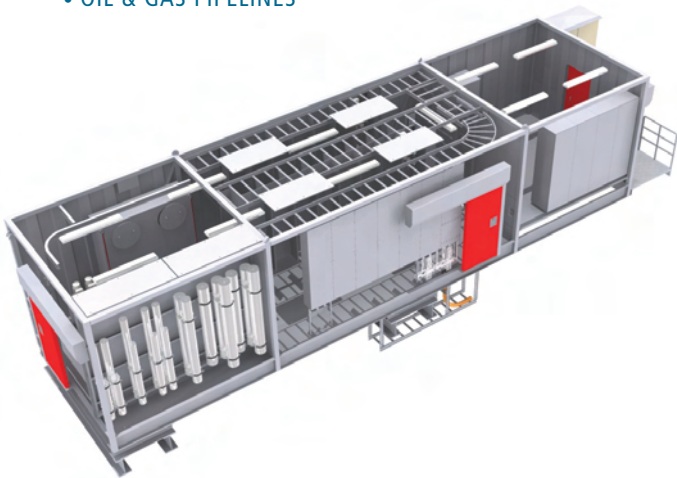

Integrated Wellhead Control System, HPU & Control Room

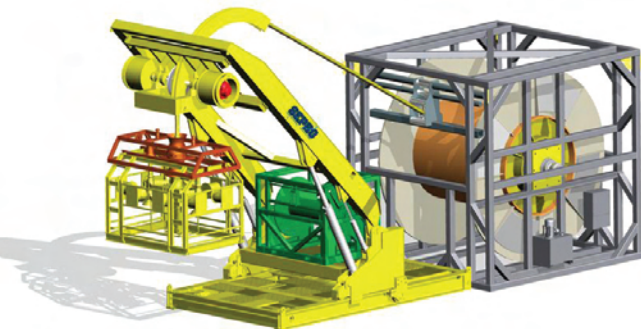

Subsea Tree Installation Workover Control System (IWOC)

We can offer complete turnkey solutions including Project Management, and a combination of inhouse production and sourcing of key components. We have the necessary human resources, operative skills and technology to be an integrated partner throughout all project stages, from conceptual design through engineering, procurement and construction to installation, commissioning and after-sales service.

Our Turnkey solutions include:

Fluid Control on Topside projects:

- Wellhead Control System
- Local Control Room
- Hydraulic Systems & Power Units
- Local Control Panels
- Ballast Control System
- Chemical Injection and dosing systems
- MEG / Methanol / Ethanol Injection skids
- Fire Fighting Systems

Subsea Control Systems:

- Installation Workover Control System
- Intervention Control Systems
- Launch & Recovery Systems (LARS)
- Umbilical & Reeler
- Deck Jumpers
- Remote Control Panels
- Production Hydraulic Power Unit
- Topside Umbilical Termination Unit
- Subsea Control Module Test Stand
- Test & Flush Equipment
- MEG / Methanol / Ethanol Injection skids



HITEC PRODUCTS

HITEC PRODUCTS AS, FORUSBEEN 222, 4313 SANDNES, NORWAY P.B. 8125, NO-4069 STAVANGER, NORWAY
P: +47 51202400 F: +47 51202401 E: MAIL@HITECPRODUCTS.NO W: WWW.HITECPRODUCTS.NO